

# Microflo<sup>TM</sup>

## Digital Fuel Management System

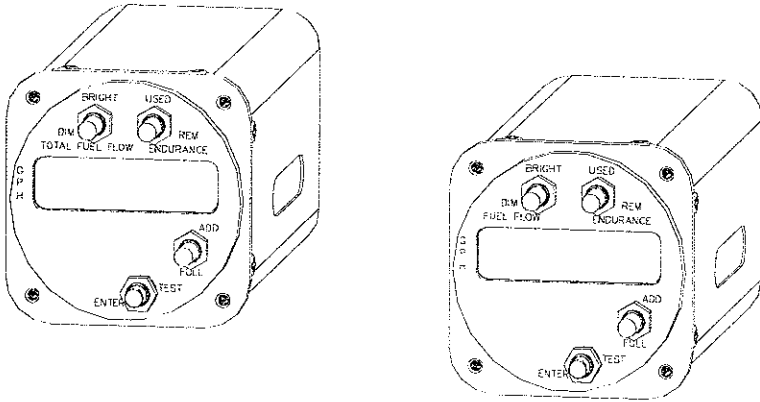

### **OPERATING MANUAL** Single and Twin Engine Indicators

For P/N: 91202X-38-D

**Shadin Co., Inc.**

# TABLE OF CONTENTS

<b>1. GENERAL DESCRIPTION .....</b>	<b>3</b>
<b>1.1 THE SYSTEM PROVIDES .....</b>	<b>4</b>
1.1.1    ENDURANCE .....	4
1.1.2    FUEL FLOW .....	4
1.1.3    FUEL USED .....	4
1.1.4    FUEL REMAINING .....	4
<b>1.2 SYSTEM COMPONENTS.....</b>	<b>5</b>
1.2.1    FUEL FLOW TRANSDUCER .....	5
1.2.2    PANEL MOUNTED UNIT.....	5
<b>1.3 TEST FUNCTION .....</b>	<b>6</b>
<b>2. PREFLIGHT PROCEDURES.....</b>	<b>7</b>
2.1 INITIAL PROGRAMMING.....	7
2.2 PREFLIGHT CHECK.....	8
2.3 NO FUEL ADDED.....	9
2.4 FUEL TANKS FULL.....	9
2.5 PARTIAL FUEL ADDED.....	10
2.6 CORRECTING FUEL ON BOARD ENTRY ERROR.....	10
<b>3. INFLIGHT OPERATIONS .....</b>	<b>11</b>
3.1 INSTRUMENT OPERATION.....	11
3.1.1    FUEL FLOW .....	11
3.1.2    FUEL USED .....	11
3.1.3    FUEL REMAINING.....	11
3.1.4    ENDURANCE .....	11

3.2 WARNINGS .....12

    3.2.1    LOW ENDURANCE .....12

    3.2.2    LOW FUEL REMAINING .....12

3.3 BRIGHTNESS CONTROL.....12

4. EMERGENCY PROCEDURES..... 12

5. ERROR MESSAGES ..... 13

6. CONFIGURATION DATA ENTRY ..... 14

7. SPECIFICATIONS ..... 19

8. WARRANTY INFORMATION ..... 20



6831 Oxford Street  
St. Louis Park, MN 55426  
U.S.A.

Sales: (800)-328-0584  
Technical Support: (800)-388-2849  
[WWW.SHADIN.COM](http://WWW.SHADIN.COM)

NOTE: Though references are made in this manual to fuel measured in gallons, the information applies equally to measurements in pounds, kilos, or liters.

# Microflo™

Although not required by the FAA, it is recommended that this manual be attached to the FAA-approved Flight Manual, or always kept on board for reference.

## 1. GENERAL DESCRIPTION

Microflo™ is a Digital Fuel Management System designed to provide complete fuel management information under real flight conditions without any manual entry of data (after entry of the initial fuel on board information).

Microflo™ is set up to measure the flow of fuel in either gallons, liters, pounds, or kilos, and it can be installed on virtually any reciprocating or turbine engine by selecting the proper size fuel flow transducer.

## **1.1 THE SYSTEM PROVIDES**

### **1.1.1 ENDURANCE**

Microflo™ calculates the time left to fly in hours and minutes based on the fuel remaining and the present fuel flow.

### **1.1.2 FUEL FLOW**

Fuel Flow is continuously displayed. The system provides a digital readout of the fuel per hour to a tenth of a gallon up to 100 gallons and to the nearest gallon above 100 gallons. For the pounds version, the readout is to the nearest pound up to 999 lbs./hour and to the nearest 10 lbs. above 999 lbs./hour.

### **1.1.3 FUEL USED**

The system keeps track of the fuel used since the last fuel entry or reset.

### **1.1.4 FUEL REMAINING**

The system keeps track of the fuel remaining on board. Fuel Remaining is equal to Initial Starting Fuel minus Fuel Used.

## 1.2 SYSTEM COMPONENTS

The system consists of two (2) basic units: the fuel flow transducer, and the panel mounted unit.

### 1.2.1 FUEL FLOW TRANSDUCER

The fuel flow transducer mounted in the fuel line measures the flow of fuel and generates electrical pulses directly proportional to the fuel flow. The transducer is fail-safe designed; rotor blockage will not interrupt fuel flow to the engine.

### 1.2.2 PANEL MOUNTED UNIT

All system electronics, function controls and digital displays are contained in a single instrument that mounts in a standard 2¼" hole. This unit requires no periodic maintenance, adjustment, or calibration once it is properly installed.

**The Display:** The fuel flow is always displayed on the left side of the display window.

**System Memory:** The system includes a non-volatile memory that retains fuel remaining and fuel used information when the power to the unit is shut down.

### 1.3 TEST FUNCTION

Diagnostic software is built into the system. To activate it, press the ENTER/TEST button until all of the display digits fill with a checkerboard pattern, and then release it. This display will flash on and off three (3) times. Next, all digits will be filled with a second checkerboard pattern, the inverse of the first, which will also flash on and off three (3) times. Careful monitoring of these patterns will verify operation of every element of the display unit.

If the test is successful, the message "GOOD" will appear in the display window for three seconds. (If the test is not successful, the message "BAD" and an error message identifying the error will be displayed. In such case, the unit will cease to function and must be considered unserviceable until corrective action is taken.) This is followed by:

- 1) The K-factor setting (Pulses Per Gallon) and units of measure the system is set to (gallons, liters, pounds or kilograms).
- 2) LT ( ): Loran or GPS Type (without signal, will display 'LOF')
- 3) The distance to waypoint or destination as shown on the Loran-C or GPS receiver to check the data interface integrity. (not available without signal)
- 4) Maximum usable fuel setting.
- 5) Software version.
- 6) If the system is not capable of reading the navigation receiver data, the message "LBD" will appear in the display window.

NOTE: a) Using the test function while the engine is running will cause the computer to lose 17 seconds of fuel count.

## **2. PREFLIGHT PROCEDURES**

MICROFLO is a fuel flow measuring system and NOT a quantity-sensing device. A visual inspection and positive determination of the usable fuel in the fuel tanks is a necessity. Therefore, it is imperative that the determined available usable fuel be manually entered into the system.

### **2.1. INITIAL PROGRAMMING**

The function of initial programming is to enter the total usable fuel into the memory. It can then be recalled whenever the fuel tanks are filled up to the maximum usable fuel. The "Full" fuel setting determines the maximum amount of fuel that can be entered by any method into the Microflo.

#### **PROCEDURE:**

1. Power the unit up.
2. Move the ADD/FULL toggle switch to the FULL position and hold for the entire procedure.
3. Simultaneously press the ENTER/TEST button and move the USED/REM toggle switch to the REM position. The system will then count down for 15 seconds, displaying the count on the left in the display window.
4. The message "FUL" and the current full fuel value will appear in the display window. Release the ENTER/TEST button and USED/REM toggle switch. Keep holding the ADD/FULL toggle switch in the FULL position.
5. Move the USED/REM toggle switch to the REM position to increment the full fuel number or to the USED position to decrement the number. (The longer you hold the switch in position, the faster the number will be updated.)



6. After reaching the correct total usable fuel figure, press the ENTER/TEST button and the computer will store that number as full fuel. The message "FUL" disappears and the computer will return to the operating mode. Release the ADD/FULL toggle switch.
7. To verify that the data is stored properly, press the ENTER/TEST button. The computer will run a diagnostic check and then display "GOOD". If the test is successful, it will display the maximum usable fuel.

**NOTE: Do not turn the power off to the computer for approximately one minute. This will ensure that the unit has enough time to store the proper figures into the program.**

## **2.2 PREFLIGHT CHECK**

Initiate the diagnostic software built in to the system by pressing the ENTER/TEST button; the program checks the hardware and the display. If the test is successful the message "GOOD" will appear in the display window; if not, the message "BAD" appears. The system is considered unserviceable until corrective action is taken.

At the end of the test routine the system will display the following:

1. Software version
2. The K-factor setting (pulse count/gallon)
3. The display units (Gal., LB 5.8, LB 6.7, etc.) as part of checking the internal settings.

Move the USED/REM toggle switch to the USED position. The system will display the fuel used since last fuel entry or fuel used since last reset.

Move the USED/REM toggle switch to the REM position. The system will display the fuel remaining on board. The pilot should confirm this figure with the actual fuel on board.

### **2.3 NO FUEL ADDED**

This automatically stores information concerning previous fuel levels, even in the case of a power down. If no fuel is added, no action is needed in updating fuel data.

### **2.4 FUEL TANKS FULL**

There are two methods to enter full fuel: the ramping method and the ADD/FULL toggle switch method.

#### **Ramping Method**

- Move the USED/REM toggle switch to the REM position and hold.
- Press the ENTER/TEST button to increment the fuel remaining until the total usable fuel is reached. (The longer you press, the faster the incrementing.)
- Release the USED/REM toggle switch and the ENTER/TEST button to enter the total usable fuel on board into memory.
- If the required figure is exceeded, follow the procedure in this manual, section 2.6 Correcting Fuel on Board Entry Error.

#### **ADD/FULL Toggle Switch Method**

- Move the ADD/FULL toggle switch to the FULL position and hold.
- Press the ENTER/TEST button.
- Release the ADD/FULL toggle switch so it returns to the center position.
- To verify, move the USED/REM toggle switch to the REM position. Total usable fuel will be displayed.

## **2.5 PARTIAL FUEL ADDED**

There are two methods to enter partial fuel:

### **Ramping Method**

Add the amount of fuel from the refueling meter to the amount of fuel remaining. Enter the total using the following steps:

1. Move USED/REM toggle switch to REM position and hold.
2. Press and hold ENTER/TEST button to increment fuel remaining until figure to be entered is reached; then release button.
3. Release the USED/REM toggle switch. The displayed figure is entered into memory as fuel remaining on board.
4. If the required figure is exceeded, follow the procedure in this manual, section 2.6 Correcting Fuel on Board Entry Error.

### **ADD/FULL Toggle Switch Method**

1. Move ADD/FULL toggle switch to ADD position and hold.
2. Move USED/REM toggle switch to REM position to increment fuel added figure until amount of fuel added is reached.
3. Press the ENTER/TEST button.
4. Release the ADD/FULL toggle switch so it returns to the center position. The computer will add the added fuel remaining and use the total as the current fuel remaining.
5. To verify, move the USED/REM toggle switch to the REM position. The current usable fuel remaining will be displayed.

## **2.6 CORRECTING FUEL ON BOARD ENTRY ERROR**

In case an error has been made by exceeding the correct amount in entering the total usable fuel, move the USED/REM toggle switch to the USED position and simultaneously press and hold ENTER/TEST button. Fuel used will be reset and the fuel remaining figure will appear and pause in the display window for four (4) seconds. The figure will decrement (the longer you press, the faster it decrements). When the correct figure is reached, release both the USED/REM toggle switch and the ENTER/TEST button. To avoid repeating the four-second pause before decrementing, hold the USED/REM toggle switch in the USED

position and use the ENTER/TEST button to control the decrementing.

### **3. INFLIGHT OPERATIONS**

#### **3.1 INSTRUMENT OPERATION**

##### **3.1.1 FUEL FLOW**

For Single Engine Aircraft: FUEL FLOW is displayed continuously on the left display window.

For Twin Engine Aircraft: Total fuel flow is displayed continuously on the left side of the display window. To read each engine's fuel flow individually, press the "REM" and "DIM" switches simultaneously.

##### **3.1.2 FUEL USED**

Fuel used is displayed by moving the USED/REM toggle switch to the USED position. The information is shown on the right display window as long as the switch is held in the USED position and for three seconds after the switch is released. The display represents the fuel used since last reset.

##### **3.1.3 FUEL REMAINING**

Fuel remaining is displayed by moving the USED/REM toggle switch to the REM position. The information is shown on the right display window as long as the switch is held in the REM position and for three seconds after the switch is released. The display represents the fuel remaining on board at the time of reading.

##### **3.1.4 ENDURANCE**

Endurance is displayed in hours and minutes on the right display window except when viewing fuel remaining or fuel used information.

## **3.2 WARNINGS**

### **3.2.1 LOW ENDURANCE**

The Microflo can be configured to display a warning based on the time remaining to fly. When the actual endurance is less than the pre-programmed Endurance Warning Time, the data in the right half of the display flashes. Press the TEST/ENTER button to acknowledge the warning. (Note: Resetting the Microflo or adding fuel resets this condition and the warning is enabled again).

### **3.2.2 LOW FUEL REMAINING**

The system displays “Lo FUEL” when the fuel remaining reaches the pre-programmed Low Fuel Level configured in setup. Fuel flow information will not be displayed again until the pilot acknowledges this message by pressing the ENTER/TEST button. Fuel calculations are not interrupted by this message. (Note: Resetting the Microflo or adding fuel resets this condition and the warning is enabled again).

## **3.3 BRIGHTNESS CONTROL**

The display brightness is controlled by the BRIGHT/DIM toggle switch. Moving the BRIGHT/DIM toggle switch to BRIGHT repeatedly will make the display brighter; moving it to DIM repeatedly will dim the display. The default brightness after power up is full brightness.

## **4. EMERGENCY PROCEDURES**

In case of electrical power failure in-flight, the instrument will cease to function. After restoring power, the system will resume accurate fuel flow reading, but time remaining, fuel used, fuel remaining, gallons reserve, gallons to destination and all warnings will not be accurate unless the duration of power failure is known and fuel consumption during the electric power failure is calculated and subtracted from fuel remaining.

## 5. ERROR MESSAGES

### ERROR 1:

Due to the necessity of *Group 1* settings, if the Flow Meter is set to Operate Mode and the checksum of *Group 1* is bad, the display will flash: **E1**.

This refers to Error 1, *Group 1*. The flow meter will not continue to function after this point, and will continue flashing **E1**, alerting the flow meter must be serviced.

NOTE: Remember it is possible to set group settings without having to be in entry mode, therefore this error can be fixed by going into *Manual Entry Mode*.

## 6. CONFIGURATION DATA ENTRY

### Manual Entry Mode

Ordinarily, the fuel flow indicator has been set up by the factory to match the K-factor of the supplied transducers and other set-up information. However, there are built-in provisions to change the set-up. Please be sure to define and document initial set-up before attempting to make changes.

#### Overview

Previously, all settings depended upon the switches mounted on the processor board. Currently, the Microflo™ processor board and software version 60.08.XX has a feature that is referred to as *Manual Entry Mode*. In this mode, the Flow Meter settings are stored as two groups: *Group 1* and *Group 2*.

*Manual Entry Mode* can be accessed in two ways: one providing access to both *Group 1* and *Group 2* values, and one providing access to only *Group 2* values. The access to *Group 2* values can be obtained while the unit is installed in the aircraft. Access to *Group 1*, however, requires removal of the unit to adjust switch settings.

*Group 1*: Generally, *Group 1* is set up by the distributor and contains information defined by the part number. However, although functions are defined here, do not change them without proper knowledge or they will affect performance of the indicator.

*Group 2*: *Group 2* must be set up by programming the unit in *Manual Entry Mode*. *Group 2* settings allow the user or installer to change input and output parameters, endurance warning time, and fuel flow filtering types.

Locations of the switches for the Microflo are as follows:

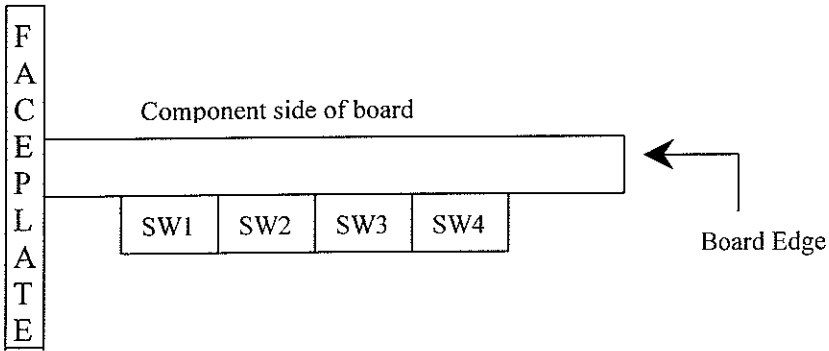

Each switch has 16 positions, 0-9, A, B, C, D, E, F.

**Operation Mode vs. Entry Mode**

**FE:** If Switch 1 is set to F and Switch 2 is set to E, the unit is in *Entry Mode*. This is the only mode that will allow the setting of Group 1 values onto the non-volatile memory of the unit. In this mode, both groups can be set. Once installed in the aircraft, this mode is no longer accessible.

**FF:** Once the settings have been programmed, Switches 1 and 2 should be set to FF. This is the *Operation Mode*, which is required for normal operations. In this mode, settings previously recorded for Groups 1 and 2 will be utilized, and not the switches. Group 2 can still be accessed through the Manual Entry Mode, but Group 1 is not accessible.

Switch	Entry Mode	Operation Mode
1	F	F
2	E	F
3	0	0
4	0	0



## Manual Entry Mode

There are two ways to access the Manual Entry Page.

1. Set Switches 1 and 2 to Entry Mode and power up. This allows access to both groups.
2. If the Switches are not set to Entry Mode, while running under normal conditions, press the TEST/ENTER button to start the test mode. When the version is displayed, press and hold the TEST/ENTER button for 15 seconds. This allows access to Group 2 only.

In both instances, "ENT" will be displayed.

The display can now be paged through using the fuel "USED" button to scroll forward or the fuel REM button to scroll back.

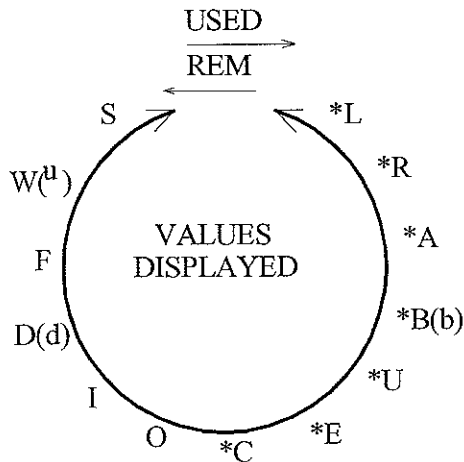

The values displayed can be adjusted with the ADD/FULL toggle switch. ADD increments the value, and FULL decrements the value. As you hold ADD or FULL, the scrolling rate will increase up to a maximum speed.

If you wish to jump directly into the fastest scrolling speed, while holding the ADD/FULL toggle switch, press the fuel USED or fuel REM button.

Once the desired values are selected, press and hold the TEST/ENTER button while the upper window displays a count down from 5 to 1. When the lower left window displays "SET," release the TEST/ENTER button.

**Note:** It is recommended that you leave the unit powered up for at least one minute before turning the unit off. Reset switches 1 and 2 to Operate Mode (F,F) and reboot (Power ON). Then confirm the settings. The Manual Entry Pages will be displayed as follows. Symbols in ( ) represent 7 segment characters actually displayed.

DisplayDescription

*L	xxxxx	=	Left K-factor (where xxxxx is valid from 0 to 20,000. These are in 10s. A setting of 1234 would be a K-factor of 12,340)
*R	xxxxx	=	Right K-factor (as above).
A	xxxxx	=	Left Fuel Flow Offset Frequency (Hz) for Analog Models Only
B(b)	xxxxx	=	Right Fuel Flow Offset Frequency (Hz) for Analog Models Only
*U	x	=	Fuel Units are defined by the part number. Do not adjust these, as improper burn indication will occur. 0 = Gallons 1 = Liters 2 = Lbs 5.8 3 = Lbs 6.7 4 = Kilograms 5 = Lbs 6.5 6 = Lbs 6.35
*E	x	=	Engine Type: 0 = Single 1 = Twin
*C	x	=	Low Flow Cutoff: 0 = Off 1 = On  NOTE: Will not display fuel flow until a rate of 50 pounds per hour is reached.
O	x	=	GPS/Output Type: Only used with Microflo-L, which selects the serial data output type by GPS or Loran Manufacturer. 0 = none 1 = Allied Signal, KLN series 2 = AirData, used to communicate with a Shadin Airdata computer 3 = Arnav, used to communicate with most Arnav Loran or GPS 4 = Trimble, used to communicate with most Trimble Loran or GPS 5 = Generic, used to communicate with most Garmin GPS
I	X	=	Loran Input: 0 = Off 1 = On
D(d)	x	=	Endurance Warning Time: 0 = 45 minutes 1 = 5 minutes 2 = 10 minutes 3 = 20 minutes 4 = 30 minutes
F	x	=	Filter Type: 0 = Injector 1 = Carburetor, for engines equipped with a carburetor
W(")	x	=	Ignore Loran Warnings 0 = No (default) setting used with Shadin Flow Meter. With GPS, set to zero (0). 1 = Ignore Loran Warnings. Used with Foster Loran only.
S	xxxx	=	Low Fuel Level: Displayed in same units of measure as the flow rate. (*) = actual letter display. All others displayed as shown

\* = Group 1 information

## 7. SPECIFICATIONS

Certification:	TSO-C44a
Maximum usable fuel:	1,800 gallons 6,822 liters 9,999 lbs @ 6.71 lb/gal 9,999 lbs @ 5.81 lb/gal 5,484 Kg @ 0.805 Kg/lit
Maximum Altitude:	40,000 ft
Operating temperature:	-30° to 50°C
Humidity:	Up to 95% @ 32°C
Accuracy:	± 2%
Ground Speed Range:	27-600 knots
Functions:	Fuel Flow (selectable endurance warning) Fuel Used Fuel Remaining Full Fuel Add Fuel Endurance

### ELECTRICAL RATING

Input Voltage:	14 – 28 VDC
Input Current:	150mA @ 14 VDC to 28 VDC

### MECHANICAL RATING

Weight:	Panel unit: 8 oz.
Dimensions:	2 ¼" x 4 ¼"
Mounting:	Instrument Panel

## 8. WARRANTY INFORMATION



6831 Oxford Street  
St. Louis Park, MN 55426

### Limited Warranty

Shadin Co., Inc. warrants this instrument and system components to be free from defects in materials and workmanship for a period of one year from the user invoice date. Shadin Co., Inc. will repair or replace any item under the terms of this Warranty, provided the item is returned to the factory prepaid.

This obligation assumed by Shadin Co., Inc. under this Warranty is limited to repair, replacement or refund of the product at the sole discretion of Shadin Co., Inc.

This Warranty shall not apply to any product that has been repaired or altered by any person other than Shadin Co., Inc. or that has been subjected to misuse, accident, incorrect wiring, negligence, improper or unprofessional assembly or improper installation by any person. **This Warranty does not cover any reimbursement for any person's time for installation, removal, assembly or repair.**

Shadin Co., Inc. retains the right to determine the reason or cause for warranty repair or replacement.

This Warranty does not extend to any aircraft, vehicle, boat, machine or any other device to which this Shadin Co., Inc. product may be installed, connected, attached, interconnected or used in conjunction with in any way.

Shadin Co., Inc. is not responsible for any shipping charges or damages incurred under this Warranty.

No representative is authorized to assume any other liability for Shadin Co., Inc. in connection with the sale or resale of Shadin Co., Inc.'s products.

*If you do not agree and accept the terms of this Warranty, you may return the product in new condition, with receipt, within thirty (30) days for a refund.*

This Warranty is made only to the original user. **THIS WARRANTY IS IN LIEU OF ALL OTHER WARRANTIES OR OBLIGATIONS: EXPRESSED OR IMPLIED. SHADIN CO., INC. EXPRESSLY DISCLAIMS ALL IMPLIED WARRANTIES OF MERCHANTABILITY OR FITNESS FOR A PARTICULAR PURPOSE. PURCHASER AGREES THAT IN NO EVENT SHALL SHADIN CO., INC. BE LIABLE FOR SPECIAL, INCIDENTAL OR CONSEQUENTIAL DAMAGES, INCLUDING LOST PROFITS OR LOSS OF USE OR OTHER ECONOMIC LOSS. EXCEPT AS EXPRESSLY PROVIDED HEREIN, SHADIN CO., INC. DISCLAIMS ALL OTHER LIABILITY TO PURCHASER OR ANY OTHER PERSON IN CONNECTION WITH THE USE OF PERFORMANCE OF SHADIN CO., INC.'S PRODUCTS, INCLUDING SPECIFICALLY LIABILITY IN TORT.**

**P/N: OP91202-38C**